

Eco Sensors OZONE CONTROLLER Model OS-6 Instructions for Use

General and New Features

The OS-6 is an industrial grade Ozone controller and monitor. The OS-6 design has been optimized for accuracy, ease of installation, setup and operation:

- All connections and controls are on the front to allow mounting of the unit before setup.
- Rugged, splash resistant enclosure and connectors for industrial environments.
- Set points for Ozone control relays are digitally controlled and are set to numeric values. This makes precise Ozone control easy to set up, even if Ozone is not currently present.
- Front panel indicator lights display a variety of important Ozone control parameters including when level exceeds 0.1ppm OSHA limit.
- Generator Control “enable” allows for disabling the generator for maintenance at the OS-6 panel.
- User selectable ranges for analog outputs (4-20 mA and 0-2 VDC)
- System failure detection and user selectable system failure condition timing.
- Full digital display.



Initial Operation

All connections between the OS-6 and the SM-4 sensor unit are made at the factory. Connect the P20 power adaptor included (US, Canada and Mexico only) or your 8-24 VDC supply to terminals + and - of the terminal block TB1. The green LED Power indicator should light and then begin blinking at 1-second intervals and Digits should show on the display. This indicates that the OS-6 is receiving sample data from the SM-4 sensing module.

Warm-up

In order to burn off any chemicals that the sensor may have absorbed during shipping and storage, you should let the OS-6 run with power on and the sensor module connected for 1 hour before response testing or overnight before the first use on site. We recommend testing the instrument for positive response with an ozone generator when the instrument is received and again at the site where the instrument is installed.

External Outputs

Terminal Blocks listed in order and descriptions.

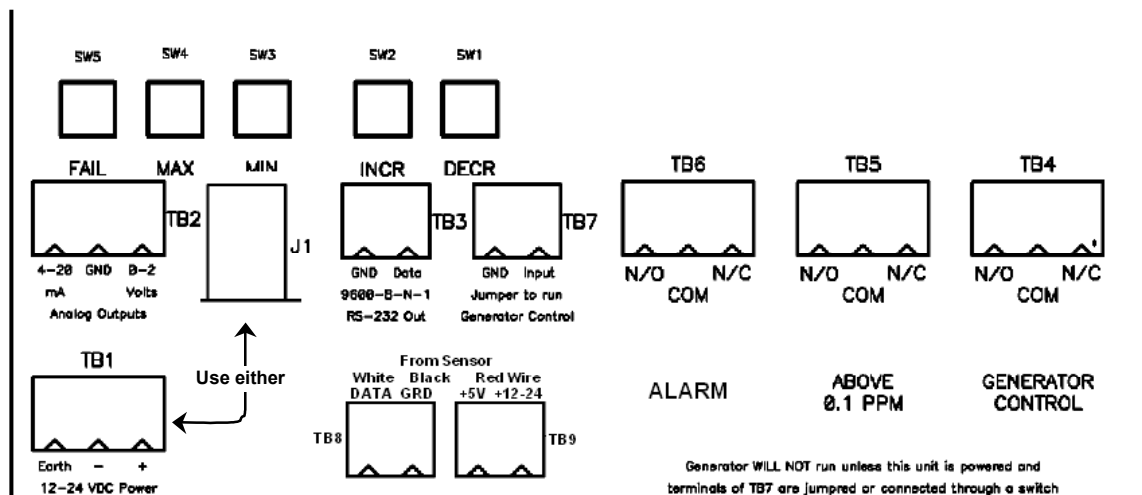

- **TB1: 12-24 VDC POWER:** Power input and earth grounding for the OS-6
- **TB2: ANALOG OUTPUT:** 4-20mA and 0-2 VDC to external control equipment. See “Analog Range Selection” section for range setup options. Default range is 0-20 PPM. [NOTE: the 4-20 mA output is a DRIVER rather than a current-sink type output.]
- **TB3: RS-232 OUT:** Serial data output. Refer to “Data Connection” instructions for details.
- **TB4: GENERATOR CONTROL:** User adjustable relay to turn off or on equipment.
- **TB5: ABOVE 0.1 PPM:** Relay tied to OSHA human safety limit.
- **TB6: UNABLE TO CONTROL OZONE:** Relay tied to Unable to Control Ozone error condition.
- **TB7: GENERATOR ENABLE:** Jumper to enable generator control. Remove to perform maintenance on the generator components. If these terminals are not connected, the generator will never run
- **TB8: Sensor Data and Ground:** Run cable from **SM-4 TB-1** Blk (grd) and WHT (data) to TB8
- **TB9: SENSOR POWER:** Power to sensor. Connect Red wire either from:
 - +5V out to **SM-4 TB1 +5V OR**
 - +12-24V out to **SM-4 TB2 12-24V+**

Do not connect '+12-24 Out' terminal on the OS-6 to the SM-4 TB1 '+5V'. This will damage the SM-4! The +12-24 terminal is in place to power the SM-4 over long cable lengths. Normally, the SM-4 will be shipped with a 6' 3-wire cable connect to TB1 +5V, BLK (grd) and WHT (data).

Indicator Lights and Display

- **Ozone:** Auto ranging digital display in PPM (Parts per Million)
- **Above MAX Limit:** On when Ozone reading above the upper set point
- **Data From Sensor:** Blinks at 1-second intervals when receiving data from Sensor.
- **Below MIN Limit:** On when Ozone reading below the lower set point.
- **Unable to Control Ozone:** This red LED activates when the system is not controlling the ozone level. It comes on if either the **Above MAX** or **Below MIN** indicator remains lit for longer than the user set **FAIL TIME**. This LED turns off when the ozone level returns to normal range. A relay operates with this indicator to provide remote alarm capability.
- **Above 0.1 Human Safety Limit:** On when reading exceeds 0.1 PPM (OSHA safety limit)
- **Generator Control:** On when relay is controlling Ozone.



Data Connection

The serial digital data stream from the SM-4 is also available for connection to a computer. Data is sent at 1-second intervals. The parameters are: **9600 bps, 8 data bits, Parity: None, Stop bits: 1, Flow Control: None**

Output example at 1PPM: Ozone, (PPB) Temperature, (Celsius) and Relative Humidity:

```
1000, 24, 34  
1000, 23, 33
```

AC Adapter

For 120 V 60 HZ areas, the Eco Sensors P-20 adapter should be used. For all other areas, adapters should be purchased locally that fit local wall sockets and conform to local codes. The output should be 12 volts DC unregulated, 300-500 mA. The plug to our instrument should fit a 5.5/2.5 mm socket with the center pin +. For further details see our Tech Note P-101.

Set Point and Alarm Condition Adjustment

Five push-buttons are mounted on the circuit board behind the wiring compartment cover. Remove cover (two screws) and locate the buttons in the upper-left corner. From left to right, they are: FAIL, MAX, MIN, INCR and DECR.

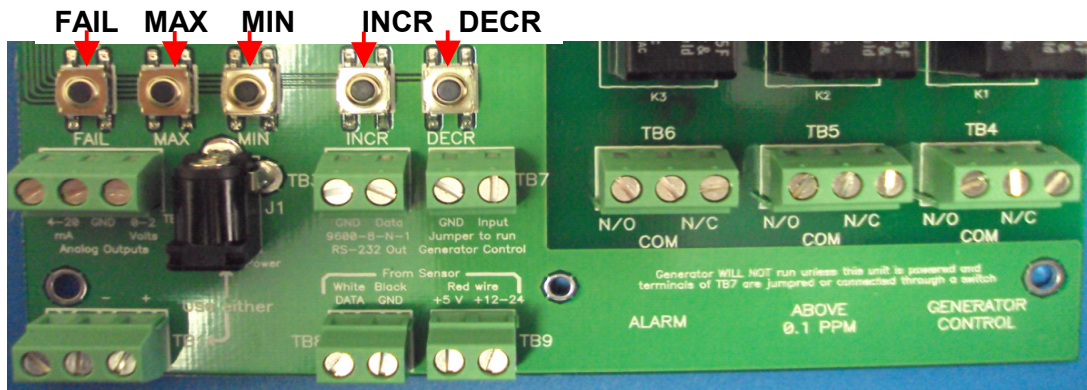

FAIL: Time (in minutes) ozone level may remain above MAX set point or below MIN set point before the "Unable to control" indicator and relay are switched on.

MAX: Maximum ozone set point, at which the generator is turned off.

MIN: Minimum ozone set point, at which the generator is turned off.

INCR: Increase set point value.

DECR: Decrease set point value.

Select the set point to change by holding down one of the first three buttons. The current value of that set point will appear on the display while the button is pressed. Press the INCR or DECR button to adjust the value. Note that MIN will not adjust higher than MAX (and vice-versa).

Analog Range Selection

Full-scale ranges for the 0-2 Volt and 4-20 mA analog outputs may be selected by adding or removing up to three push-on jumpers on header J4, which is located on the back of the display circuit board. Access this area by removing four screws from the display bezel.

Jumpers	A	B	C	Range selected
	OFF	OFF	OFF	0-2 PPM
	ON	OFF	OFF	0-5 PPM
	OFF	ON	OFF	0-10 PPM
	ON	ON	OFF	0-20 PPM
	ON	OFF	ON	0-50 PPM
	ON	OFF	ON	0-100 PPM
	OFF	ON	ON	0-200 PPM
	ON	ON	ON	0-500 PPM

IMPORTANT NOTE: The range of an OS-6 is limited by the sensor module. The currently available SM-4 operates from 0-20 PPM. Higher ranges may be available on future sensor modules. Please contact Eco Sensors for details.

Specifications

Wall mounted polycarbonate enclosure resists water spray and splash (NEMA 4X).

Size: H = 6.3"/160mm, W = 6.5"/166mm, D = 4.6"/118mm.

Wiring: Conduit or cable gland knock-outs along bottom of enclosure.

Power in: 12-24 VDC.

Power out: +5 or +12-24 VDC to sensor.

Data in: RS-232 serial data from remote sensor module (SM-4 or equivalent).

Data out: RS-232, 9600 Baud 8N1 format.

Analog out: 0-2 V and 4-20 mA, full scale range settable by internal jumpers.

Control in: Generator enable (contact closure).

Control outputs: Relays, 10A @ 25VDC, 0.25A @ 250VDC, 2.0 KVA AC (resistor).

Relay functions: Ozone generator control, >100 PPB safety limit, failure to control.

User controls (internal): MAX setpoint, MIN setpoint, FAIL time, increase, decrease.

Numeric display: Four digits, 0.5"/12mm, auto-ranging, with backlight.

LED indicators: Sensor, above MAX, below MIN, >100 PPB, generator on, failure.

Service and Maintenance

Do not attempt to perform board level repairs or microprocessor programming. This will void the warranty. We recommend checking the calibration monthly and replacing the sensor module annually. The unit should be returned to Eco Sensors for repairs or performed by an Eco Sensors authorized service representative. **Tampering with or attempting repairs to the unit will void the warranty.**

Calibration of the sensor on its board (SM-X) is done electronically in a specially constructed facility at the factory. Therefore it is more cost effective to replace the SM-X board than to request that it be recalibrated.

Instruments with problems during the warranty period should be returned as a system (OS-6 and SM-4) to the factory or authorized service representative for diagnosis and repair.

Appendix A:

Wiring Illustration (OS-6 Rev 4.0):

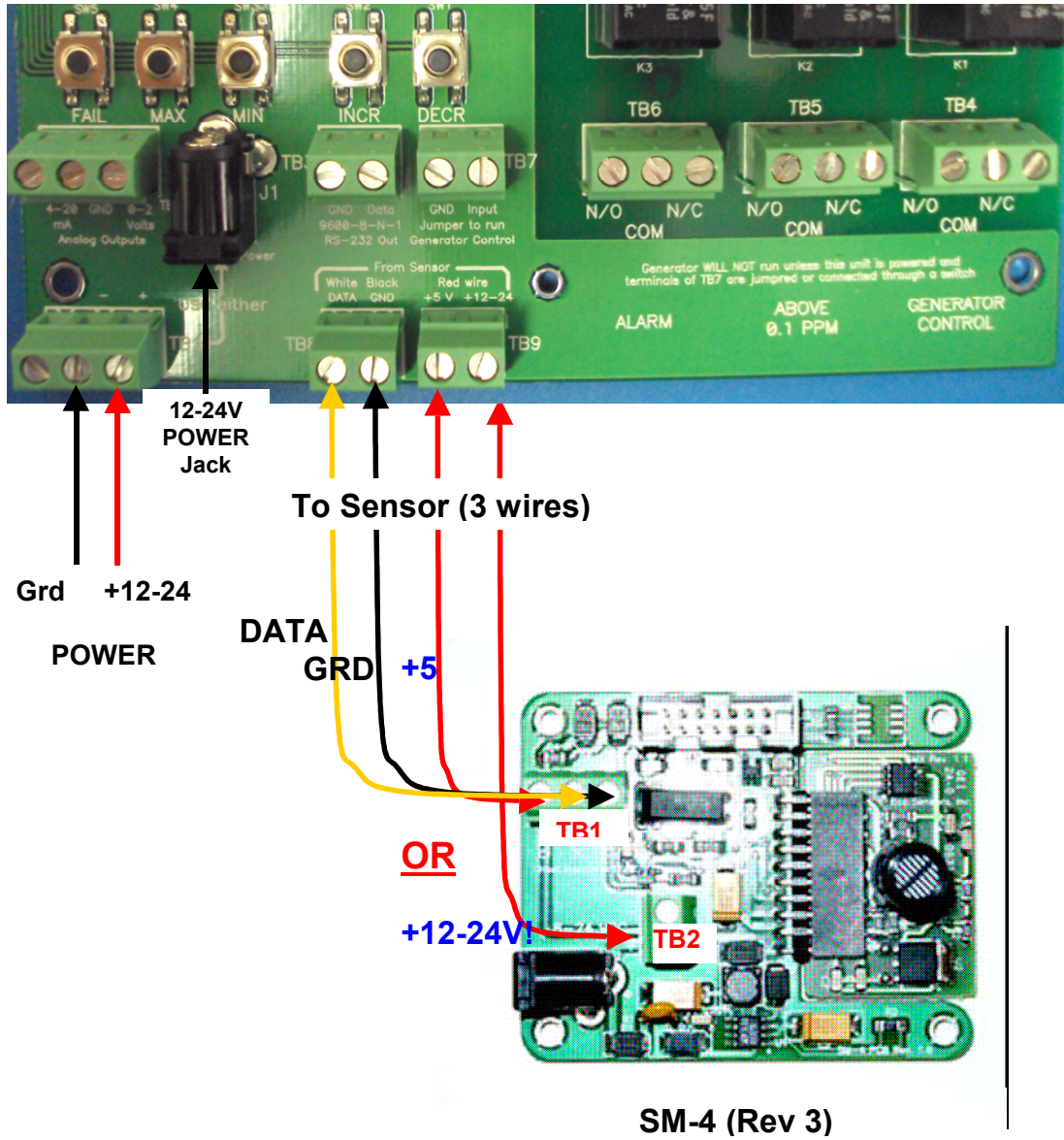

APPENDIX B

CONNECTING OS-6 RS232 OUTPUT TO COMPUTER

Connections:

The connections from the OS-6 to the serial COM port of a PC are as follows:

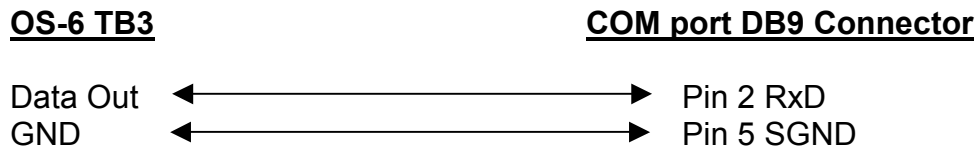

The output data stream is OUTPUT ONLY at 1-second intervals. There is no input from the PC to the OS-6.

Example Terminal Setup in Windows

The terminal program in Windows is HyperTerminal. It is located in **Start>>All Programs>>Accessories>>HyperTerminal**

1. Open HyperTerminal

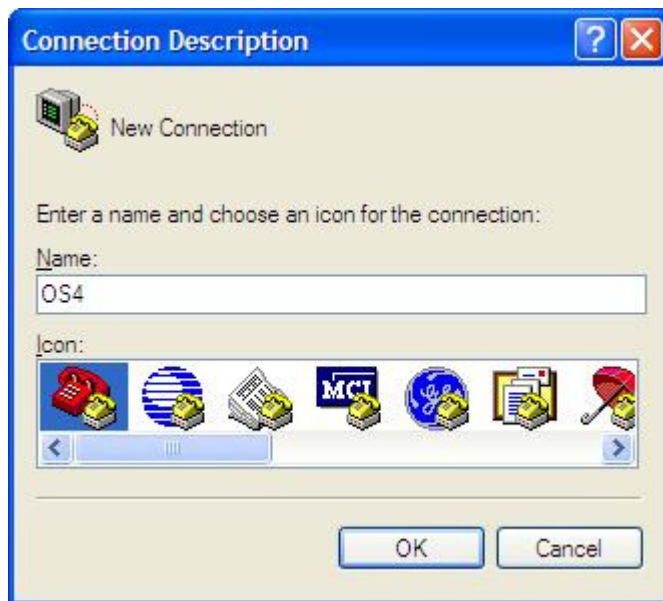

2. Enter COM port to be used:



3. Enter the serial communications parameters as shown:

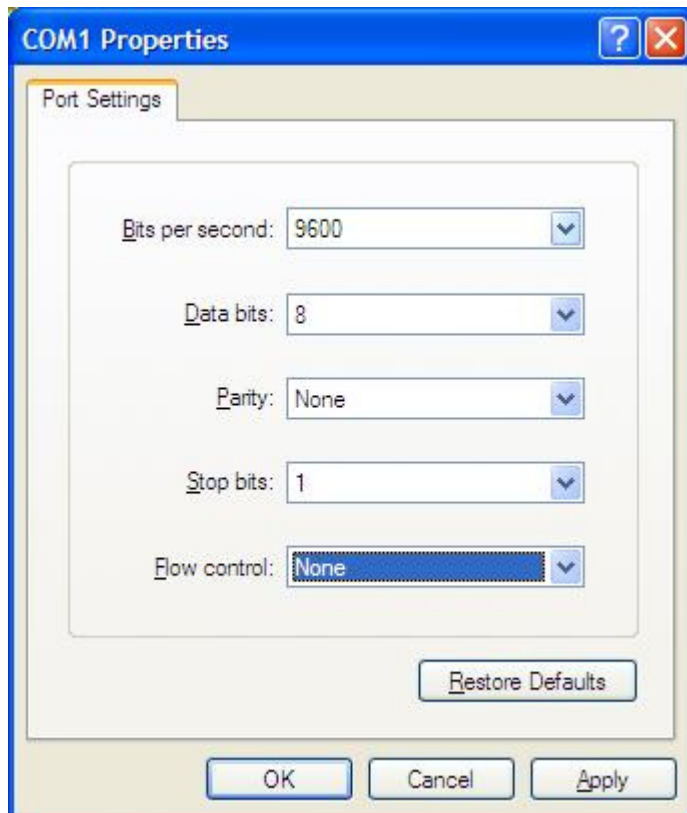

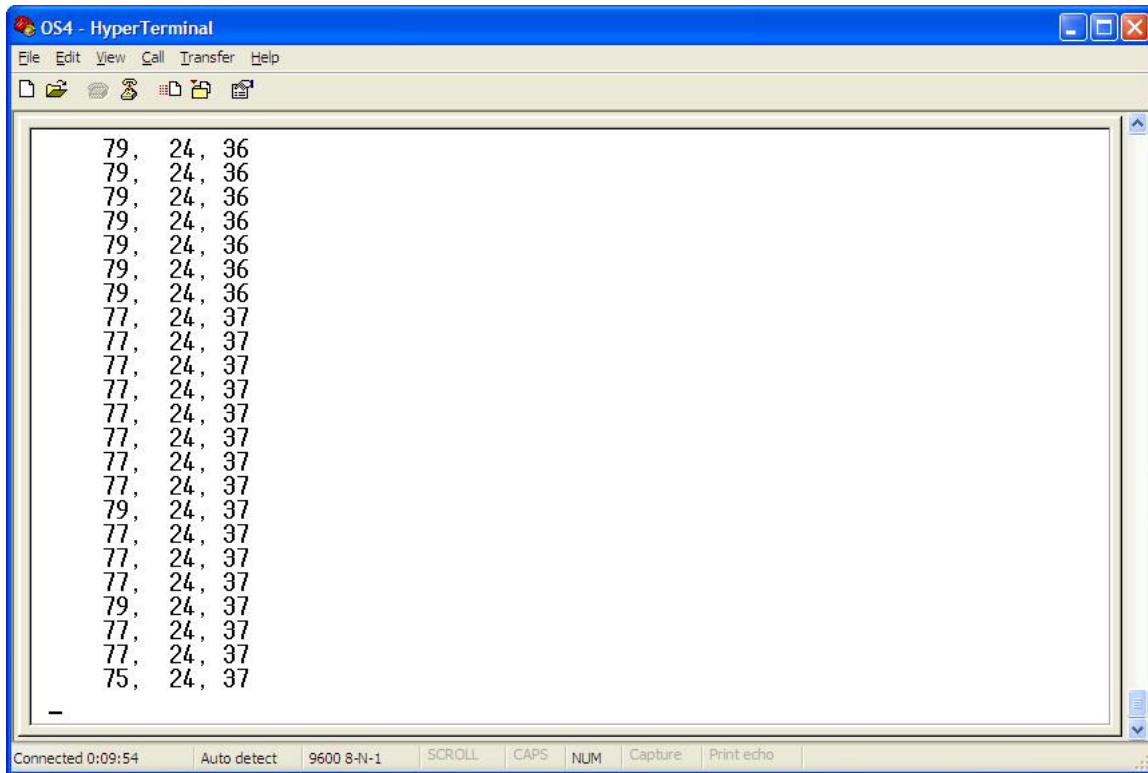

Output shown: 0.079PPM (79 ppbv), 24 degrees C, 37% Relative Humidity. The OS-6 outputs one data point every second.

Appendix C

Typical OS-6 Application Diagram (For reference purposes only)

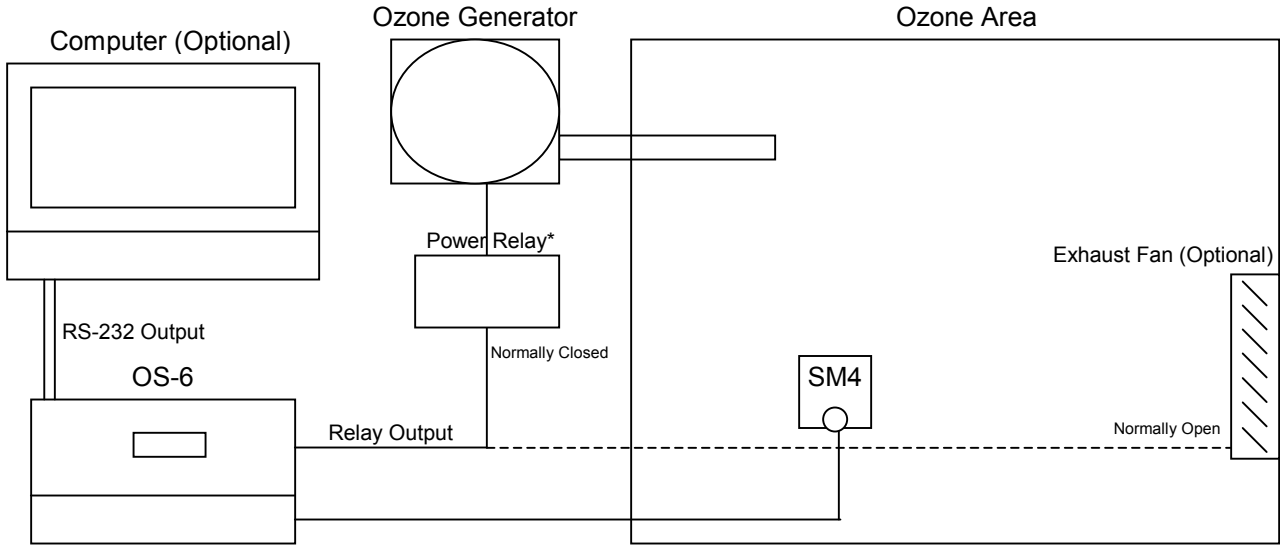

*Power relay is required if Ozone generator load exceeds OS-6 relay ratings.

WARRANTY

This product is warranted against defects in materials and workmanship for one year following the date of purchase by the original owner. This warranty does not include damage to the product that results from misuse, accident, dropping, modifications or alterations, and it does not apply if the instructions in this manual are not followed, or if the unit is otherwise used outside its intended specifications.

If a defect develops during the warranty period, Eco Sensors, in its sole discretion, will repair the instrument or replace it with a new or reconditioned model of equivalent quality. In the event of replacement with a new or reconditioned instrument, the replacement unit will continue the warranty of the original unit.

If the product should become defective during the warranty period, please return it through your distributor, or call Eco Sensors at (800) 472-6626 or e-mail at sales@ecosensors.com to receive return instructions and a Return Materials Authorization (RMA) number.

Except as provided herein, Eco Sensors makes no warranties, express or implied, including warranties of merchantability and fitness for a particular purpose. Eco Sensors shall not be liable for loss of use of this instrument or other incidental or consequential damages, expenses or economic loss, or claims for such damage or economic loss.

RECORD YOUR SERIAL NUMBER HERE _____

KEEP THIS MANUAL AND WARRANTY FOR YOUR RECORDS.

Eco Sensors is a registered trademark of Eco Sensors div of KWJ Engineering, Inc.
© Eco Sensors div of KWJ Engineering, Inc. 2010. OS-6 REV 2, SM-4 and SM-X,
Manual rev 07/10

For brochures, application and tech notes, and other useful information, visit our extensive website at www.ecosensors.com. E-mail us at sales@ecosensors.com.